

FC4500/FC5500/FC5700/FC4700 to FC4700-2 Storage Systems

Conversion Guide

P/N 014003074-A01

This document explains how to upgrade a Model FC4500, FC5500, FC5700, or FC4700 disk-array processor enclosure (DPE) to a Model FC4700-2, 2-gigabit DPE. It outlines how to replace power supplies and storage processors (SPs), and then describes how to initialize the SPs.

Topics are:

- Requirements 2
- Upgrade Kit..... 4
- Related Documentation 4
- Converting the Hardware 5
- Initializing an FC4700-2 Storage System..... 14

Only an authorized EMC service provider should perform the conversion procedure described in this document.



CAUTION

This conversion procedure DOES NOT support the transfer of data between FC4500/FC5500/FC5700 systems and the FC4700-2.

Requirements

- The Fibre Channel SAN and attach environment must support the FC4700-2 prior to the conversion. Refer to the *CLARiiON® Open Systems Support Matrix for FC4500, FC4700, FC5300, and FC5700*.
- Your host HBA or switch environment must match the new array's Fibre Channel speed *before* converting to an FC4700-2. You should set switches to autonegotiate FC speed.
- The server host bus adapters (HBAs) and cables must support optical attach components. The FC4700-2 DPE is optical only.
- The FC4700-2 requires new optical cables with LC connectors to replace the SC-connector cables used on previous SPs.
- Your FC4700-2 connect topology must be either direct connect or fabric-switch (no hub).
- The Disk Processor Enclosure (DPE) you will upgrade must have two Link Control Cards (LCCs) and be connected to two Standby Power Supplies (SPSs). All attached DAEs must have two LCCs and two power supplies as well.
- All management software and host attach software must be at a supported revision for the FC4700-2. Refer to the Open System Support Matrix for these revisions.
- The Navisphere® Management Station must be running Navisphere revision 5.2.5 or later prior to conversion.
- Each FC4700-2 SP (2 per array) must have a TCP/IP network connection, and the Navisphere Management Station must be on this network. You will connect the SPs to this network during the setup procedure.
- You will need a service (usually laptop) computer with the following:
 - Windows NT® 4.0 with Service Pack 5 or Windows® 2000
 - Navisphere Manager, CLI revision 5.2.5
 - Remote Access Server
- You will need a null modem cable with 9-pin, female connectors.
- You will need two .5-meter cables (P/N 118025170) per DAE for DAE-to-DAE connection.

- FC4700 arrays must be running Base Software at revision 8.43xx or above *before you begin* conversion to an FC4700-2.

IMPORTANT To preserve any data on FC4500/FC5500/FC5700 systems, you must back up the data prior to the conversion. After the FC4700-2 initialization, you must perform a complete restore of the preserved data.

FC4700-to-FC4700-2 conversions are “data in place” operations. As a precaution, you should always back up required data prior to any major procedure.

Confirm that the system you are converting contains only the storage-system disks shown in Table 1. If not, replace the disks with supported drives.

Table 1 Disk Drives Supported in FC4700-2 Arrays

Vendor	Disk (P/N)	Description
Seagate	005045266	9 Gbyte, 7200 rpm
	005045270	9 Gbyte, 10K rpm
	005045715	9 Gbyte, 10K rpm
	005045934	9 Gbyte, 10K rpm
	005045268	18 Gbyte, 7200 rpm
	005045272	18 Gbyte, 10K rpm
	005045932	18 Gbyte, 10K rpm
	005046630 ^a	18 Gbyte, 15K rpm
	005046730	18 Gbyte, 10K rpm
	005045936	36 Gbyte, 10K rpm
	005046732	36 Gbyte, 10K rpm
	005046734	73 Gbyte, 10K rpm
	005047169	73 Gbyte 10k rpm
IBM	005045713	18 Gbyte, 10K rpm
	005045719	36 Gbyte, 7200 rpm

a. Only supported in DAEs using power supplies with part number and revisions at or above 005042633-21 or 005045508-04

The disk part number (005 number) appears on a label either on the side or the front of the plastic carrier, as shown in Figure 1.

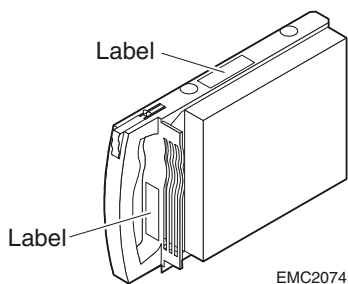

Figure 1 Location of Part Number on Disk Drive

Upgrade Kit

The FC4700-2 Upgrade Kit contains the following:

Items	Part Number
2 SPs, each with 1 Gbyte of memory	005047390
2 650-W power supplies	005047396
Base Software media and documentation	005047381
EMI shield gasket kit	005047515
2 1-M Fibre Channel cables	118027372
1 cabinet cabling diagram	002055929

Related Documentation

- *FC4700-2 Rackmount Model Hardware Reference* (P/N 014003072)
- *EMC Navisphere Manager Version 5.X Administrator's Guide* (P/N 069001036)
- *EMC Fibre Channel Storage System Model FC4700-2 Configuration Planning Guide* (P/N 014003082)
- *CLARiiON Open Systems Support Matrix for FC 4500, FC4700, FC5300, and FC5700* (available on MySalesWeb at home> site director> products> Interoperability> Matrices)

Converting the Hardware



CAUTION

The following procedure assumes any data on an FC4500/FC5500/FC5700 array is of no future value, because data will not be preserved.

Perform the following steps to convert an FC4500, FC5500, FC5700, or FC4700 storage system to an FC4700-2 DPE.

1. Verify that the Navisphere Management Station is running Navisphere Manager revision 5.2.5 or later.
2. If you are converting an FC4700 array, verify that the FC4700 is running Base Software revision 8.43.xx or later, and all related layered drivers and applications.
3. Power down the storage system.
4. Confirm that all drives in the array are supported by the FC4700-2; replace any drives not listed in Table 1 on page 3.
5. Label and disconnect all cables connected to the storage processors (SPs).
6. Remove the power supplies from the DPE enclosure.

Refer to Chapter 4, *Servicing and Upgrading a DPE*, in the *FC4700-2 Rackmount Model Hardware Reference*. The power supply removal procedure is the same for all these systems.

7. Install the new FC4700-2 power supplies (P/N 005047396).

Refer to Chapter 4, *Servicing and Upgrading a DPE*, in the *FC4700-2 Rackmount Model Hardware Reference*.

8. Remove the SPs from the DPE enclosure.

Refer to Chapter 4, *Servicing and Upgrading a DPE*, in the *FC4700-2 Rackmount Model Hardware Reference*. The SP removal procedure is the same for all these systems.

9. Install the new EMI shield gasket in the lower SP enclosure, as shown in Figure 2 and Figure 3.
 - a. Use needle-nose pliers to remove the EMI clips from the SP enclosure (see Figure 2).

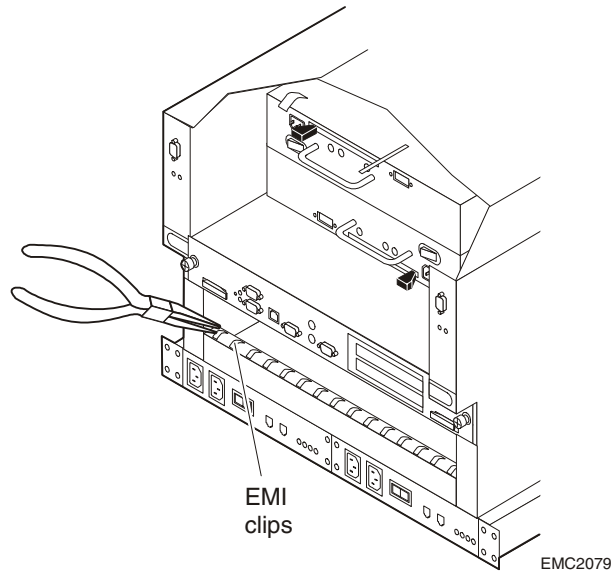

Figure 2 Removing the EMI Clips

- b. Remove the paper backing from the gasket adhesive, and then install the EMI gasket between the lines of holes that held the EMI clips. Refer to Figure 3.

Install the gasket with the adhesive strip to the *rear* of the machine (toward you).

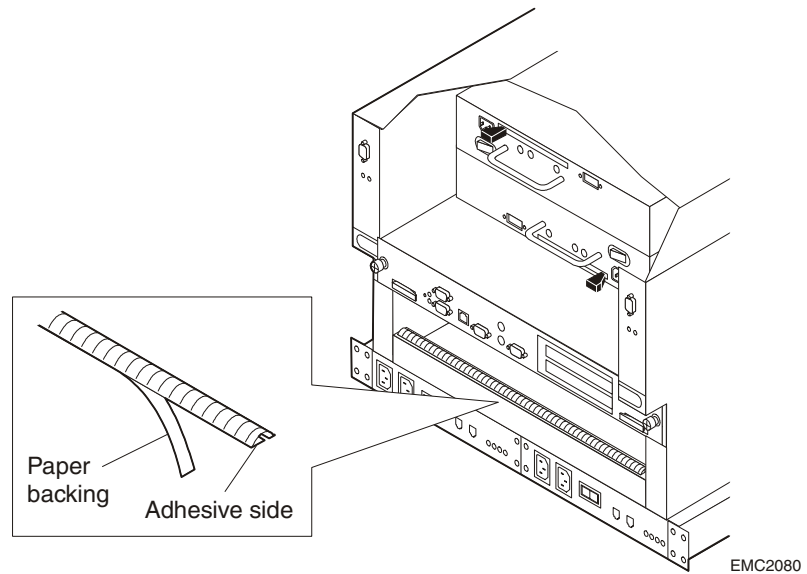

Figure 3 Installing the SP Enclosure EMI Gasket

10. Install the new FC4700-2 SPs.

Refer to Chapter 4, *Servicing and Upgrading a DPE*, in the *FC4700-2 Rackmount Model Hardware Reference*.

11. Re-cable the DAEs using the cabling information in Figure 5 or Figure 6.

The upgrade kit includes the necessary SP-to-DAE cables. The SP-to-DAE cables are 1-m cables (P/N 118027372). The DAE-to-DAE cables are 0.5-m cables (P/N 118025170). These are not included in the kit, but should have been ordered separately.

Systems that require a second cabinet (for example, configurations with more than 100 disks) need a 10-meter DAE-to-DAE cable (P/N 11825172) to connect the buses between cabinets, as shown in Figure 6.

12. If necessary, (re-)set the DAE Enclosure Addresses (EAs). On Bus 0, the DPE has a fixed EA of 0, which cannot be changed. Set the first DAE on Bus 0 to EA 1, the next to EA 2, and so on. On Bus 1, set the first DAE to EA 0, the second to 1, and so on. See Figure 4, Figure 5, and Figure 6 as necessary.

Resetting the Enclosure Addresses is required for all upgrades other than FC4700 to FC4700-2.

Bus 0 begins at the LCCs of the DPE. Bus 1 begins at the SP ports.

FC4700-2 Base Software does not recognize EAs of greater than 5 on either bus. This limits the total disk count to 120 drives, 60 per bus.

Refer to the *EMC Fibre Channel Storage System Model FC4700-2 Configuration Planning Guide* for detailed information.

Set the DAE enclosure address on the EA switch behind the front door *when power is not applied to the chassis* (for example, configuring prior to turning system power on).



CAUTION

You should NOT change the enclosure address while the system is active.

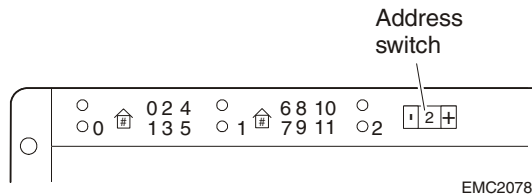

Figure 4 Changing the EA on a DAE

Figure 5 and Figure 6 show sample DPE/DAE bus, enclosure address, and cabling configurations.

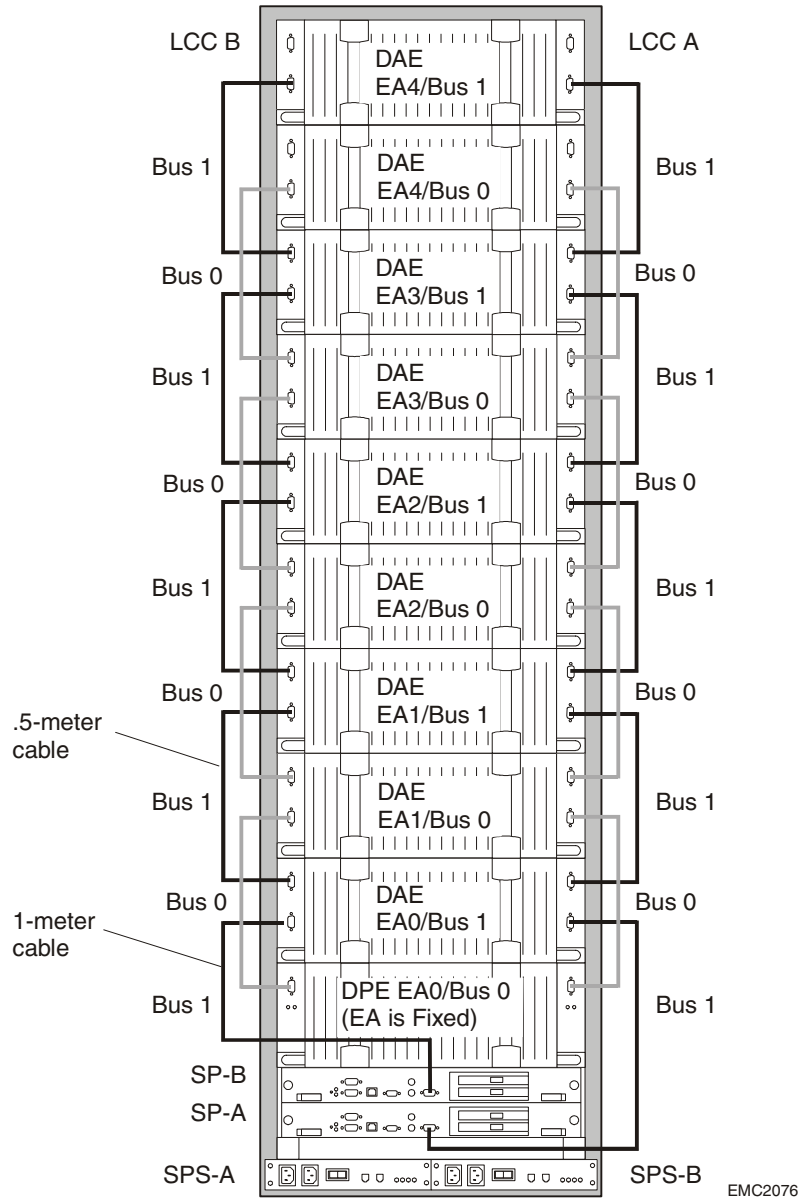
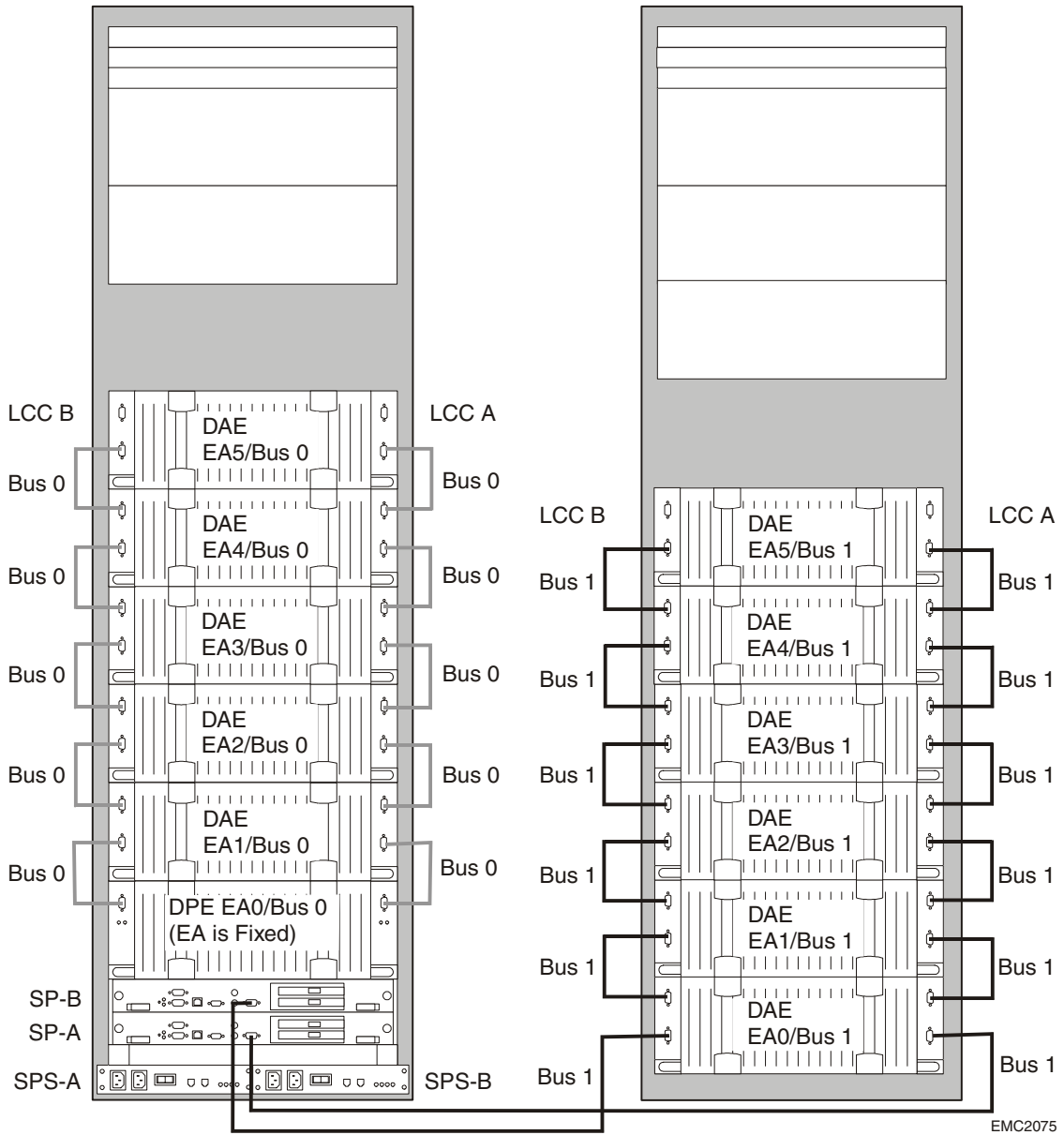

Figure 5 Sample DPE and DAE Cabling in a Single-Cabinet Installation

Figure 6 shows the recommended cabling scheme for a system that spans two cabinets.

Note that this configuration simplifies cabling by separating the busses into individual cabinets.



EMC2075

Figure 6 Sample DPE and DAE Cabling in a 2-Cabinet Installation

13. Cable the SPs to the SPSs. Power up the storage system and verify that the status LED on the front of each SP shows normal green (not amber).

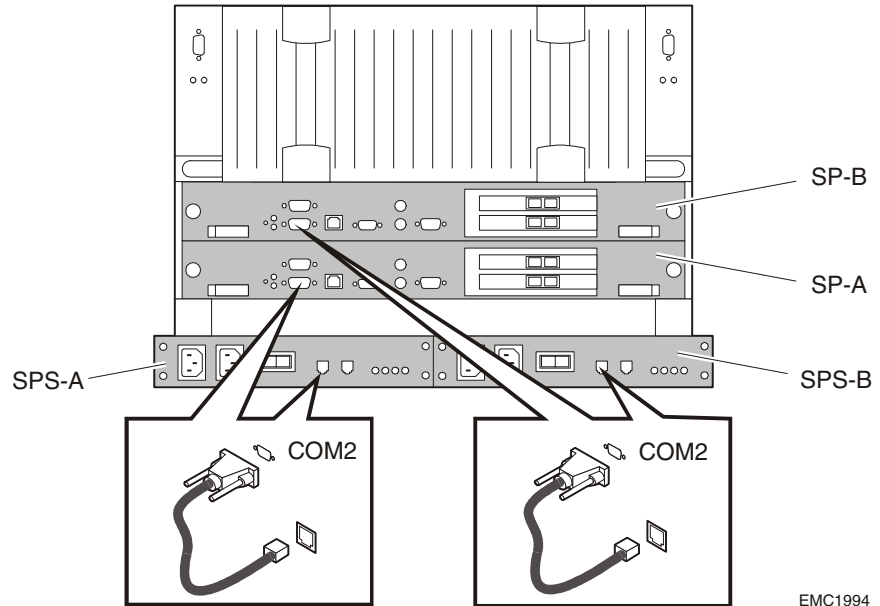

EMC1994

Figure 7 SP to SPS Cabling

14. Connect the new LC-connector Fibre Channel cables from the switch or server to port 0 or port 1 on the SP as shown in Figure 8.
 - a. Remove the protective covers from the connectors and cables.
 - b. Plug the cables into the SP host ports.
 - c. Connect the other end of the Port 0 (top) cable as follows:
 - For *direct attach* configurations — to the host server’s host bus adapter (HBA).

Make certain the 2-gigabit HBA is installed in the host server before you connect the SP.

- For *Storage Area Network (SAN)* configurations — to a Fibre Channel switch port.
 - d. Connect the other end of the Port 1 (bottom) cable as follows:
 - On a system *without MirrorView™* — to an HBA port (direct-attach configurations) or switch port (SAN configurations).
 - On a system *with MirrorView* — to Port 1 of the corresponding storage processor (SP) on the remote storage system, or to a switch that has been properly zoned to the mirror port of the remote array.

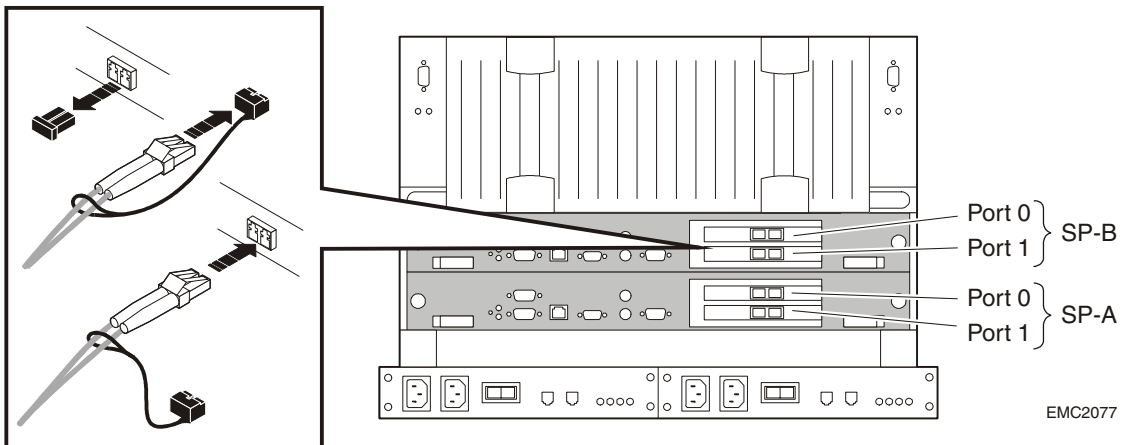

Figure 8 Reconnecting the Fibre Channel Cables

EMC2077

At the completion of the hardware conversion, each DPE chassis in your system should include two SPs, two SPSs, two LCCs, and two power supplies. Each DAE should include two LCCs and two power supplies.

Returning the Original SPs and Power Supplies

EMC Customer Service has detailed instructions for proper return and accounting of the replaced storage processors and power supplies. Please arrange with EMC Customer Service for return of the FC4500, FC5500, FC5700, or FC4700 SPs and power supplies.

Initializing an FC4700-2 Storage System

This section explains how to set critical startup parameters on the FC4700-2 SPs.

IMPORTANT If you are converting an FC4700 array to an FC4700-2 array, skip the initialization process and go directly to Step 48 on page 21.

PSM LUN Configuration Rules

Before beginning the initialization process, please note the following Persistent Storage Manager (PSM) LUN configuration rules.

- The PSM LUN must be a redundant RAID type completely housed in the DPE chassis.
- A RAID 1 or RAID 5 PSM LUN must have at least one drive that is not a database (DB) drive.
- A RAID 3 PSM LUN must have 5 or 9 drives, at least one of which is not a database drive.
- A 4-drive RAID 1/0 PSM LUN can use only one database drive when using Base Software 8.41.04.
- A 4-drive RAID 1/0 PSM LUN can use up to two database drives when using Base Software 8.41.09 or higher.

Database (DB) drives are the first three drives in the DPE chassis (drives 0-2).

What These Configuration Rules Disallow

The PSM LUN configuration rules disallow a:

- RAID 0 PSM LUN.
- RAID 1 PSM LUN of drives 0 and 1.
- RAID 1 PSM LUN of drives 1 and 2.
- RAID 1 PSM LUN of drives 0 and 2.
- 3-drive RAID 3 PSM LUN of drives 0 through 2.
- 3-drive RAID 5 PSM LUN of drives 0 through 2.
- 4-drive RAID 1/0 PSM LUN where two or three of the drives are DB drives, Base Software 8.41.04.

- 4-drive RAID 1/0 PSM LUN where all three of the DB drives are used, Base Software 8.41.09 or higher.

PSM LUN Placement

The following rules apply to PSM LUN placement:

- The PSM LUN can be on a RAID group with other LUNS.
- THE PSM LUN should be considered a “high use” LUN during the planning for LUN distribution across RAID groups/disk drives.
- As with any other “high use” LUN, the PSM LUN should share disk drives (RAID groups) with other LUNs that will not heavily compete with each other for I/O access to the drives.
- You should distribute high and low use LUNs across RAID groups, and balance the load.

By default, Navisphere Manager automatically selects drives 2-6 in the DPE chassis group and creates a RAID 5 PSM LUN in that group. To create a PSM LUN on other drives in the array, select **Support RAID Type** in the **PSM Admin Bind LUN** dialog box.

Initializing the Storage System

Follow the steps below to initialize the FC4700-2 storage system.

1. Set up the service laptop as described in Chapter 3 of the *FC4700-2 Rackmount Model Hardware Reference*. Make certain it includes Navisphere Manager revision 5.2.5 or higher.
2. On the service laptop, follow the path:
Start→Programs→Admin Tools→User Manager
The **User Manager** dialog box opens.
3. From the **User** menu, select **New User**.
4. Create a new user account called **clariion1992**, with the password **clariion1992**.

You must fill in the **Confirm Password** field.

5. Check the **Password Never Expires** box.
6. Click **Groups**.
The **Group Memberships** dialog box appears.

7. Assign this account dial-in and administrator privileges.
8. Click **OK**.
9. Click **Dial-in**.
The **Dial-in** dialog box appears.
10. Check the **Grant dial-in permission to user** box.
11. Click **OK**.
12. Modify the laptop's TCP/IP network settings to use DHCP as follows:
 - a. Right-click **Network Neighborhood**, and then select **Properties**.
 - b. Click the **Protocols** tab.
 - c. Select **TCPIP**, and then click **Properties**.
 - d. Note your current settings so that you can restore them later.
 - e. Click **Obtain an IP address from DHCP Server**, and when prompted for confirmation, click **Yes**.
 - f. Click **OK**.
 - g. In the **Network** dialog box, click **OK**.
 - h. When prompted to reboot, click **Yes**.
13. Unplug any network connections to the laptop.
14. Log in to the laptop as user **clariion1992** with the password **clariion1992**.
15. Connect the null modem cable between the laptop (port COM 1) and the SP-A service port COM 1, as shown in Figure 9.

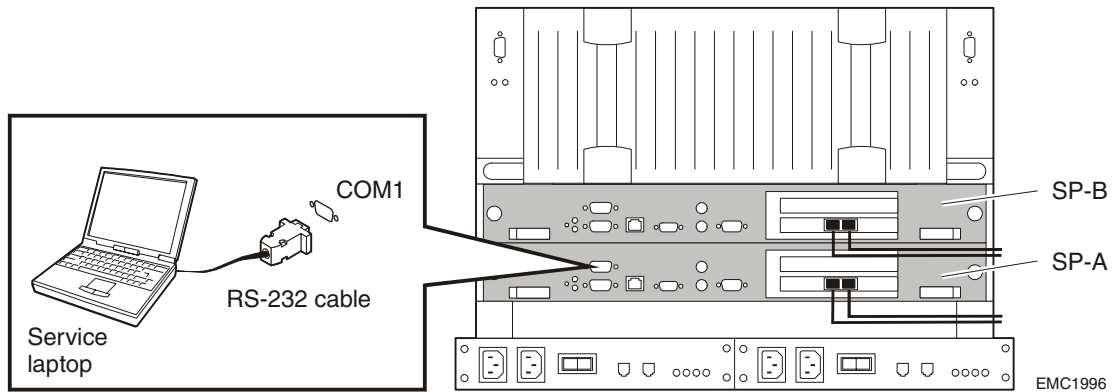

Figure 9 SP COM 1 Port

16. On the laptop, follow the menu path **My Computer →Dial-up Networking**.
17. Select the phonebook entry you created when you set up the laptop in the previous section.
18. Click **Dial**.
19. In the **Connect to** dialog box, log in as user **clariion** with password **clariion!**. Ignore the Domain field.
20. Click **OK**.
21. Start Navisphere Manager.
22. Follow the menu path **File →Select Agents**, and in the **Agent to Add** field specify the SP's IP address, which is **192.168.1.1**.
23. Click the arrow next to the IP address to add the SP to the Managed Host field.
24. Click **OK**.
25. Click **OK** in the **Storage System Management Warning** dialog.
26. Verify that you have read the PSM LUN restrictions on page 14 before proceeding.

27. Create a PSM LUN as follows:

a. Right-click the storage system on which you want to create a PSM LUN.

b. Select **Initialize Array**.

The **PSM Admin Bind LUN** dialog box opens.

c. Specify a valid RAID type that the customer wants (for example, RAID 5) and specify the disks for the PSM LUN.

See "PSM LUN Configuration Rules" on page 14.

d. Click **OK**.

e. The **PSM Admin Bind LUN** dialog box appears. Click **Yes**, then click **OK**.

Wait for the PSM LUN bind to complete.

28. Use the following command to set the chassis/array serial number:

```
navicli -h 192.168.1.1 arraysernum -messner <serialnumber>
```

The serial number can be found on a sticker on the top of the DPE chassis. It is the letter F, followed by eleven (11) digits.

29. Next you must specify Privileged Users for the storage system. You can do this using CLI or Navisphere Manager. If you are using Navisphere Manager, skip to Step 30.

The list should include every person who will administer the storage system (including the login for the laptop).

Use the form *username@hostname*; for example, **admin@pc1234**. At least one hostname must match the Navisphere Management Station hostname.



CAUTION

If a privileged user is not specified during initial setup of the storage system, anyone can manage that storage system.

a. Bring up a DOS command prompt by following the menu path **Start → Programs → Command Prompt** or **Start → Run → cmd**.

- b. Go to the directory containing the navicli files by entering:
c:\program files\emc\Navisphere cli
 - c. Use the following command to add each privileged user:
**navicli -h 192.168.1.1 remoteconfig -setconfig
-adduser *username@hostname***
 - d. When the CLI prompts for confirmation, answer **Y** for yes.
 - e. Repeat step 29c for each privileged user you want to add.
30. To specify Privileged Users in Navisphere Manager, perform the following procedures.

The list should include every person who will administer the storage system (including the login for the laptop).

Use the form *username@hostname*; for example, **admin@pc1234**. At least one hostname must match the Navisphere Management Station hostname.

- a. In the **Enterprise Storage** dialog box, click the **Storage** tab.
 - b. Click the storage system for which you want to display the SPs.
 - c. Right-click the icon for the SP (A or B) to which you want to add privileged users, then click **Properties**.
 - d. Click the **SP Properties - Agent** tab.
 - e. Under **Privileged Users**, click a blank line.
 - f. In the text box that appears, type the name of the privileged user.
 - g. Click **Apply** in the **Agent** tab to save your changes. Click **OK** to save your changes and close the **SP Properties** dialog box.
31. Use the following CLI command to set the cache defaults:
navicli -h 192.168.1.1 setcache -wc 1 -p 8 -L 80 -h 96
32. Answer **Y** to confirm.
The SPs will reboot two times.
33. Repeat steps 15 through 19 to reconnect to SP-A and start Navisphere Manager.
34. In the **SPS Properties** dialog box, set the SPS test.

35. Click **OK**.
36. From the **Array Properties** dialog box under the **General** tab, confirm the chassis ID is valid.
37. Using the **Network** tab in the **SP Properties** dialog box, specify the SP-A hostname, IP address, subnetmask, and gateway address.

The customer will provide you with the names desired for the SP-A hostname and the correct subnetmask and gateway address.

38. From the **General** tab, set the date and time for SP-A.
39. Click **OK**. You will be asked to confirm your changes. Ensure that the settings are correct, then click **Yes** twice.

SP-A reboots.

40. Connect the laptop COM 1 port to the SP-B COM 1 port using the NULL cable.
41. Establish a PPP connection to SP-B using steps 15 through 19 in this section.
42. Use Navisphere Manager's **Network** tab in the **SP Properties** dialog box to specify the SP-B network information as in steps 37 and 38. You will be asked to confirm your changes. Ensure that the settings are correct, then click **Yes** twice.

SP-B reboots.

43. Connect the LAN cables to the SP for Navisphere management as shown in Figure 10.

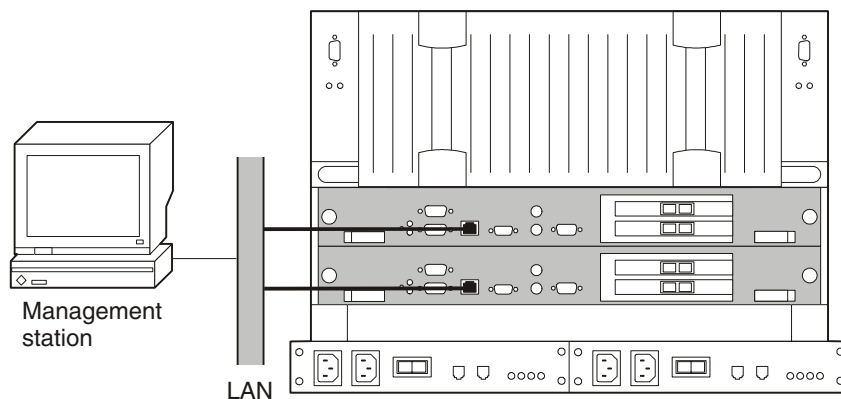

EMC1991

Figure 10 Connecting the LAN cable

44. Log in or have the customer log in to a Navisphere Management station connected to an FC4700-2.
45. Use Navisphere Manager to manage both SP agents as follows:
 - a. Follow the menu path File →Select Agents.
 - b. In the **Agents to Add** field, specify the SPs' IP addresses that the customer provided in steps 37 and 42 above.
46. Using the **ALPA** tab in the **SP Properties** dialog box, set the ALPA SCSI ID value for each port of SP-A and SP-B.
The SP reboots after each ALPA you set.
47. If you need to set the SCSI ID of another SP port, repeat step 46.

Set the Desired FC Speed for Each Port on SP-A and SP-B

48. Using the **Fibre Speed** tab on the **SP properties** dialog box, change the fibre speed for each SP port as follows:

Note: You may set the ports on an SP to operate at different speeds.

- a. In the **Enterprise Storage** dialog box, click the **Storage** tab.
- b. Double-click the icon for the storage system component and then right-click the SP component for which you want to set the SP port speed.
- c. Click **Properties**, then click the **Fibre Speed** tab.
- d. Under **Current Settings**, select the speed for each port.
- e. Click **Apply** or **OK** to save the changes.
- f. If an SP is connected directly to a host bus adapter (HBA), refer to the HBA documentation.
49. Confirm that both SPs are running the latest Base software.
50. Make certain all software packages are committed.
 - a. In Navisphere Manager, check the **Software** tab of the **Array Properties** selection for any software packages requiring a **COMMIT**.
 - b. Perform the commit if necessary.
51. Install any layered software, such as SnapView™ or MirrorView. For further information, refer to the *Navisphere Manager Administrator's Guide*.

IMPORTANT If you are converting an FC4500, FC5500, or FC5700 system to an FC4700-2, you must install Access Logix *before* the SnapView or MirrorView software.

You have initialized an FC4700-2 storage system. The next step is for the customer to set up a Navisphere Management Station. If possible, keep the service laptop handy until the management connections have been tested.

Copyright ©EMC Corporation 2001. All rights reserved
Revision A01, October, 2001

This document and the related software product are the exclusive property of EMC Corporation and may be used only by users properly licensed to use the software product and only according to the terms of that license. Use of the software product constitutes acceptance of those license terms.

Trademark Information

EMC², EMC, CLARiiON, and Navisphere are registered trademarks and Access Logix, MirrorView, and SnapView are trademarks of EMC Corporation. All other trademarks mentioned herein are the property of their respective owners.